

U.S. Des. Pat. No. D693,200

The Veritas® Prairie Dog™ is sized to fit into $\frac{3}{4}$ " diameter through-holes in workbench tops* between 2" and 2½" thick. This brass stop features a height-adjustable spring mechanism that will raise the dog head (about $\frac{5}{16}$ " projection) when in use and lower it to stow it when not needed.

**Note: For thicker tops, a dowel spacer can be used. See below for details.*

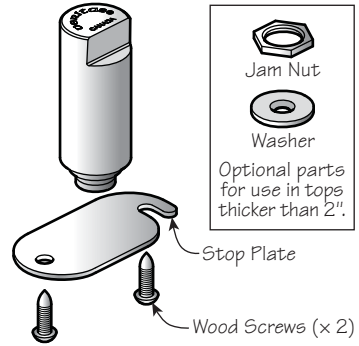

Figure 1: Prairie dog parts.

Installing the Stop Plate

For use in a through-hole, you will need to fasten the stop plate to the underside of the workbench top; a magnet at the base of the dog holds it firmly against the plate. To free up the hole for other duty, the plate is easily pivoted out of the way, and the dog removed.

Select a dog hole for the desired location of the prairie dog. Using the stop plate as a guide, mark the locations for the screw holes on the underside of the workbench. Drill two $\frac{3}{32}$ " pilot holes for the screws. Install the plate with the two included wood screws, bringing each screw head up against the plate, but not so tight as to prevent the plate from being rotated out of the way to free up the hole.

Additional plates may be installed to allow a single prairie dog to be used in multiple locations.

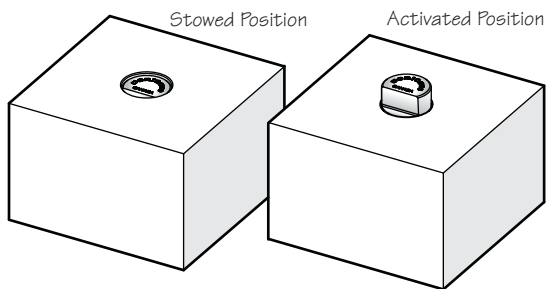

Figure 2: Prairie dog pops up for use.

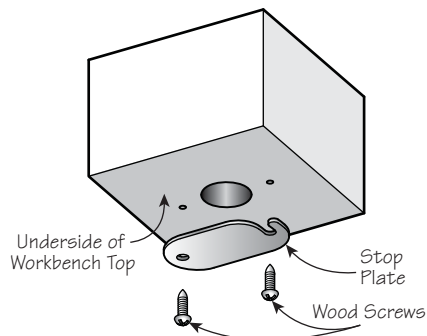

Figure 3: Plate installation.

Adjusting the Projection

For use in a through-hole in a 2" thick workbench top, the projection of the prairie dog does not need to be adjusted; it can be used as received. For use in thicker workbench tops, you will need to adjust the projection, as noted below.

1. For use in workbench tops thicker than 2" (but less than 2 1/2" thick), unscrew the spring mechanism, add the included jam nut, and reinsert the spring mechanism. Adjust the dog post to the desired height, then lock the setting by winding the jam nut up the mechanism until the jam nut is flush with the dog post.

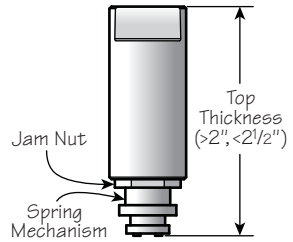

Figure 4: Prairie dog used in workbench tops thicker than 2".

2. For workbenches thicker than 2 1/2", you can insert a dowel spacer between the stop plate and the prairie dog. Cut a length of 3/4" diameter dowel 2" less than the thickness of your workbench top. To retain the magnetic feature, fasten the included countersunk washer to one end of the dowel with a #4 flat-head screw. With the plate in place, insert the dowel spacer (washer-side up) into the dog hole, then insert the prairie dog.

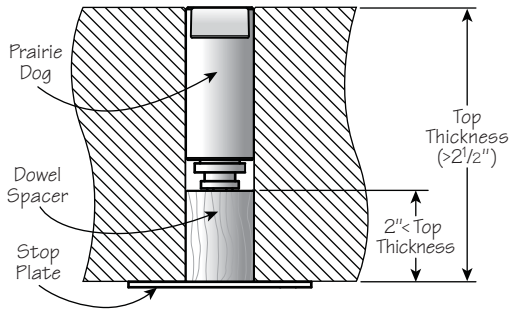

Figure 5: Prairie dog used with dowel spacer.

3. For use in a blind hole, the stop plate is not required. For workbenches thicker than 2" (but less than 2 1/2" thick), you can fasten the included countersunk washer to the bottom of the blind hole with a #4 flat-head screw if the magnetic feature is desired. For use in a blind hole in a workbench top thicker than 2 1/2", you can insert a dowel spacer at the bottom of the blind hole.

Accessories

05G10.24 Stop Plates, pkg. of 4

veritas® Tools Inc.

814 Proctor Avenue 1090 Morrison Drive
Ogdensburg NY 13669-2205 Ottawa ON K2H 1C2
United States Canada

customerservice@veritastools.com

www.veritastools.com